

Описание на проточные флуориметры. Серия OilGuard 2 Ex

По вопросам продаж и поддержки обращайтесь: ssg@nt-rt.ru www.sigrisnt-rt.ru

Архангельск (8182)63-90-72,
Астана+7(7172)727-132,
Белгород(4722)40-23-64,
Брянск(4832)59-03-52,
Владивосток(423)249-28-31,
Волгоград(844)278-03-48,
Вологда(8172)26-41-59,
Воронеж(473)204-51-73,
Екатеринбург(343)384-55-89,
Иваново(4932)77-34-06,
Ижевск(3412)26-03-58,
Казань(843)206-01-48,
Калининград(4012)72-03-81,
Калуга(4842)92-23-67,
Кемерово(3842)65-04-62,
Киров(8332)68-02-04,

Краснодар(861)203-40-90,
Красноярск(391)204-63-61,
Курск(4712)77-13-04,
Липецк(4742)52-20-81,
Магнитогорск(3519)55-03-13,
Москва(495)268-04-70,
Мурманск(8152)59-64-93,
НабережныеЧелны(8552)20-53-41,
НижнийНовгород(831)429-08-12,
Новокузнецк(3843)20-46-81,
Новосибирск(383)227-86-73,
Орел(4862)44-53-42,
Оренбург(3532)37-68-04,
Пенза(8412)22-31-16,
Пермь(342)205-81-47,
Ростов-на-Дону(863)308-18-15,

Рязань(4912)46-61-64,
Самара(846)206-03-16,
Санкт-Петербург(812)309-46-40,
Саратов(845)249-38-78,
Смоленск(4812)29-41-54,
Сочи(862)225-72-31,
Ставрополь(8652)20-65-13,
Тверь(4822)63-31-35,
Томск(3822)98-41-53,
Тула(4872)74-02-29,
Тюмень(3452)66-21-18,
Ульяновск(8422)24-23-59,
Уфа(347)229-48-12,
Челябинск(351)202-03-61,
Череповец(8202)49-02-64,
Ярославль(4852)69-52-93

OilGuard Ex

On-line Oil in Water Analyzer



Applications

- Produced water discharge or reuse monitoring
- Monitoring effectiveness of oil separators
- Detection of oil leakage into cooling water/waste water
- Slop tank overboard discharge monitoring

Industries

- Crude oil production offshore & onshore
- Refineries
- Petrochemicals
- Power plants
- Ship building

Advantages

- Well-proven UV-Fluorescence measuring principle
- True non-contact measurement in a free-fall stream
- Dual-beam optics for highest accuracy and stability
- Integrated operation panel with touch screen, color display and data logger
- Flexible, modular system
- Fast recalibration with checking unit
- Minimum maintenance requirements
- Correlates to any International recognized standard reference method

OilGuard Ex

On-line Oil in Water Analyzer

Innovations with real benefits



Modular design

The system design can be tailored to suit specific installation requirements:

- 3 various measuring cells.
- Select a single analyzer or a complete pre-mounted system.
- Optional sample conditioning system, including pumps are available.
- Optional integrated sampling station for QC purpose.

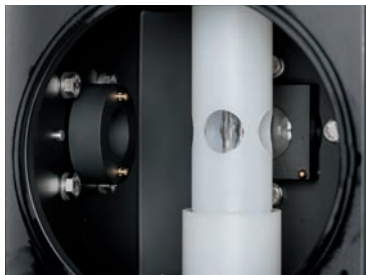

Lowest cost of ownership Negligible maintenance

SIGRIST's well-proven true non-contact measuring concept prevents the entire system from scaling. This leads into an amazing long maintenance interval:

- No ultrasonic cleaning device is needed.
- The negligible maintenance is quick and easy no special tooling is required.

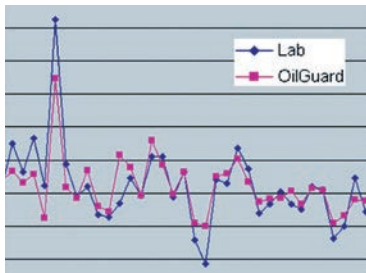

Reliable measurement

The instrument uses a sophisticated dual-beam optical setup with optimized wavelength configuration:

- Guarantees highest accuracy and stability of the measurement.
- Fluctuations and light source ageing are automatically compensated.
- The relevant HC components are measured.
- Reduces the impact of solids.



Instant reading verification

Quick reading verifications and instrument recalibration with the unique secondary solid reference standard from SIGRIST:

- No chemicals are needed for recalibration or cleaning.
- No special tooling is required.

Integrated control unit

The control unit in the OilGuard is based on an integrated colour touch screen:

- Values, graphs, alarm- and status messages can be presented upon customer desire.
- An internal data logger allows recalling and displaying measured data of the last 32 days.

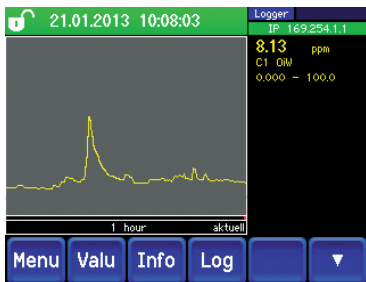

Technical Data

OilGuard Ex Oil in Water Analyzer:

Measuring principle:	UV-Fluorescence
Measuring span:	0 .. 100 FLU 0 .. 1000 ppm oil ^{*1)} 8, freely configurable
Measuring ranges:	0.001 FLU ^{*2)}
Resolution:	+/- 0.002 FLU / +/- 2 % ^{*2)}
Reproducibility:	< 2 s (step response → limit switch)
Response time:	On-line side stream
Installation:	Inlet: 3/4" NTP / 16 mm Outlet: 2" NTP / 50 mm
Sample connection:	PVDF
Material, wetted parts:	316L SS / 1.4404
Material housing:	1.3 .. 1.9 gpm / 5 .. 7 l/min
Sample flow rate:	atmospheric
Sample pressure:	max. +203 °F / +95 °C
Sample temperature:	-4 .. +104 °F / -20 .. +40 °C (with cooling system max. 122 °F / 50 °C)
Ambient temperature:	0 .. 100% RH
Ambient humidity:	IP66
Protection degree:	Ex px ib IIC T4 Gb
Ex protection class:	230V 50/60 Hz, 100/115/130V
Power supply:	65 W
Power input max:	14 x 20 x 27"
Dimensions:	35 x 50 x 70 cm (W x L x H) 82 lbs. / 37 kg
Weight:	
Operation:	
Display:	1/4VGA, 5.7"
Operation panel:	Touchscreen
Outputs:	1 x 0/4 .. 20 mA, galv. separated 2 x relay contacts, 3 x digital, freely configurable
Inputs:	4 x digital, freely configurable
Digital Interface:	Ethernet, Modbus TCP microSD-card
Optional:	Hart, Profibus DP, Modbus RTU

Accessories:

- Sample conditioning system
- Sample feed pump
- Sample return pump
- Mounting rack
- Integrated statutory sampling point

*1) Depending on the oil characteristics

*2) Referred to quinoline sulfate in water

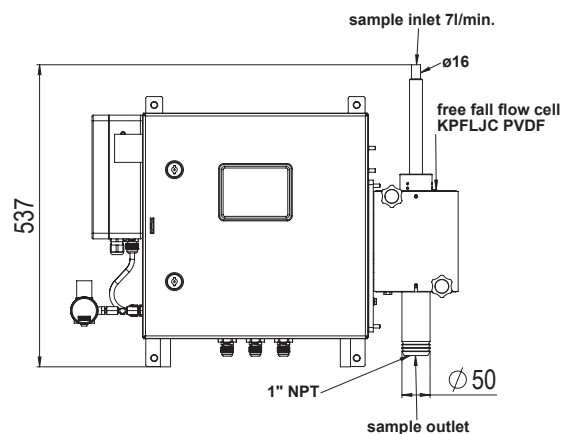

По вопросам продаж и поддержки обращайтесь: ssg@nt-rt.ru www.sigrist.nt-rt.ru

Архангельск (8182)63-90-72,
Астана+7(7172)727-132,
Белгород(4722)40-23-64,
Брянск(4832)59-03-52,
Владивосток(423)249-28-31,
Волгоград(844)278-03-48,
Вологда(8172)26-41-59,
Воронеж(473)204-51-73,
Екатеринбург(343)384-55-89,
Иваново(4932)77-34-06,
Ижевск(3412)26-03-58,
Казань(843)206-01-48,
Калининград(4012)72-03-81,
Калуга(4842)92-23-67,
Кемерово(3842)65-04-62,
Киров(8332)68-02-04,

Краснодар(861)203-40-90,
Красноярск(391)204-63-61,
Курск(4712)77-13-04,
Липецк(4742)52-20-81,
Магнитогорск(3519)55-03-13,
Москва(495)268-04-70,
Мурманск(8152)59-64-93,
НабережныеЧелны(8552)20-53-41,
НижнийНовгород(831)429-08-12,
Новокузнецк(3843)20-46-81,
Новосибирск(383)227-86-73,
Орел(4862)44-53-42,
Оренбург(3532)37-68-04,
Пенза(8412)22-31-16,
Пермь(342)205-81-47,
Ростов-на-Дону(863)308-18-15,

Рязань(4912)46-61-64,
Самара(846)206-03-16,
Санкт-Петербург(812)309-46-40,
Саратов(845)249-38-78,
Смоленск(4812)29-41-54,
Сочи(862)225-72-31,
Ставрополь(8652)20-65-13,
Тверь(4822)63-31-35,
Томск(3822)98-41-53,
Тула(4872)74-02-29,
Тюмень(3452)66-21-18,
Ульяновск(8422)24-23-59,
Уфа(347)229-48-12,
Челябинск(351)202-03-61,
Череповец(8202)49-02-64,
Ярославль(4852)69-52-93